

The TL model knife gate valve is a bi-directional wafer type through-conduit valve designed for media with high consistency. The double seat design assures a non-clogging shut off on suspended solids in both flow directions. The valve is used in a wide range of demanding applications in industries such as Pulp & Paper, Wastewater Treatment Plants, Chemical plants, Power Plants, etc.

Product description:

- Bi-directional wafer type through-conduit knife gate valve
- Size range of DN50-1000 (larger sizes upon request). See Dimension Charts for pressure rating
- Rising & non-rising stem configurations available
- Standard flange connection: DIN PN10 (EN 1092-2) and ANSI B16.5 (class 150)
Others available upon request
- Manual (handwheel, chainwheel, lever and bevel gear), pneumatic (single and double-acting), electric and hydraulic actuation options available
- For EU Directives and other Certificates, please see the document:
Directives and Certificates Compliance - Knife Gate Valves - Catalogues and Datasheets

Features:

- Wafer type cast two-part bolted body. HMWPE sliders included in the stainless steel version for a smoother gate traveling
- Full port design for greater flow capacity and minimal pressure drop
- Stainless steel o-port design through-going gate, polished both sides to avoid jamming and seat damage
- Standard EPDM resilient seat. Metal-to-metal seat, as well as high performance rings and deflection cones available
- Dual packing with easy access and adjustable packing glands ensuring a tight seal. Long life PTFE impregnated synthetic fiber plus EPDM O-ring. Wide range of packing materials available
- RAL-5015 blue epoxy-coating on all cast iron/carbon steel components
- Automated valves provided with gate guards in accordance with EU Safety Standards
- Other options: bonnets, V-ports, flush ports, special materials, fabricated valves, etc.
- Actuation accessories: limit & proximity switches, mechanical stops, positioners, solenoid valves, manual overrides, locking devices, fail safe systems, stem extensions and floor stands

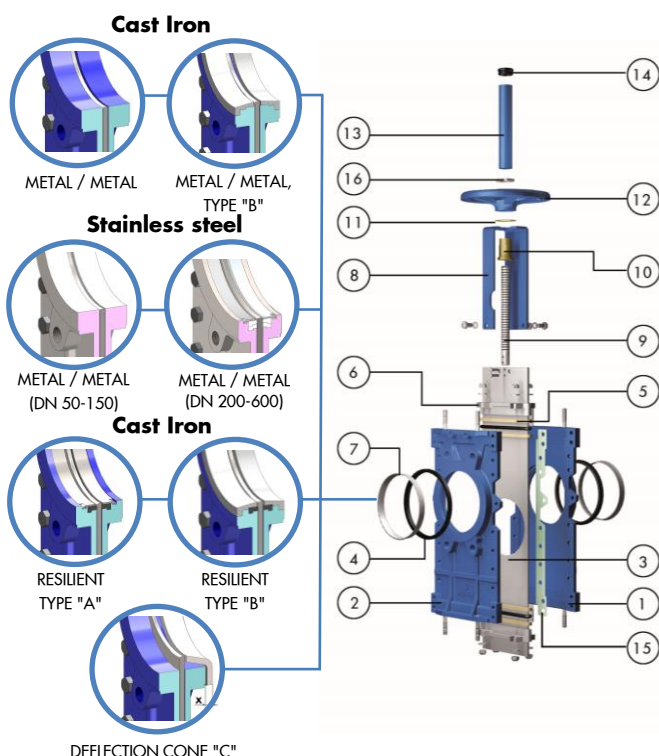

STANDARD PARTS LIST

Part	Material
1 Body	GJL250 / GJS400 / CF8M
2 Body	GJL250 / GJS400 / CF8M
3 Gate	AISI 304 / AISI 316
4 Seat	Metal or EPDM
5 Packing	PTFE impreg. synth. fibre (ST)+O-ring
6 Gland Follower	Al (DN50-300) - Ductile Iron (DN350-1000) / CF8M
7 Seal Retainer Ring	AISI 304 / AISI 316
8 Yoke	Carbon steel - Epoxy coated
9 Stem	Stainless Steel
10 Stem Nut	Brass
11 Friction Washer	Brass
12 Handwheel	GJS400 (GGG40)
13 Stem Protector	Epoxy-coated carbon steel
14 Cap	Plastic
15 Gasket	Aramid fibres
16 Nut	Zinc plated carbon steel

DIMENSIONS (mm) Handwheel Rising Stem

DN	Pressures	A	B	C	D	E	F	ØG	H	Ø max.	Weight (kg.)
50	10 bar	40	152	100	110	129	47	225	429	232	12
65	10 bar	40	167	100	115	146	47	225	451	255	14
80	10 bar	50	182	100	124	162	47	225	476	310	16
100	10 bar	50	202	100	140	187	47	225	517	367	20
125	10 bar	50	216	100	150	211	47	225	601	432	29
150	8 bar	60	241	100	175	237	47	225	652	497	35
200	8 bar	60	294	122	205	309	67	310	822	635	62
250	8 bar	70	356	122	245	364	67	310	1017	777	89
300	6 bar	70	410	122	280	414	67	310	1102	905	110
350	6 bar	96	473	197	300	486	66	410	1286	1047	174
400	6 bar	100	538	197	350	536	66	410	1386	1171	266
450	5 bar	106	588	201	420	588	66	550	1583	1301	326
500	4 bar	110	646	201	450	648	66	550	1673	1461	372
600	4 bar	110	754	201	530	748	66	550	1963	1711	445

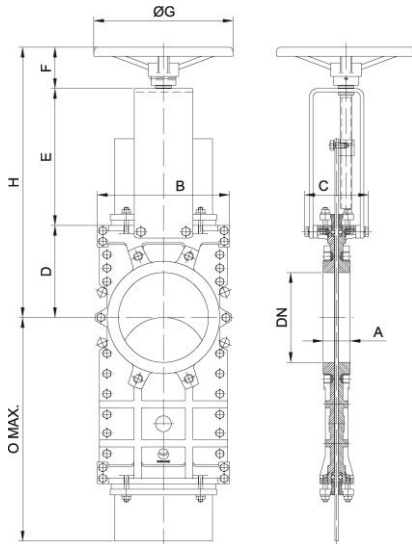
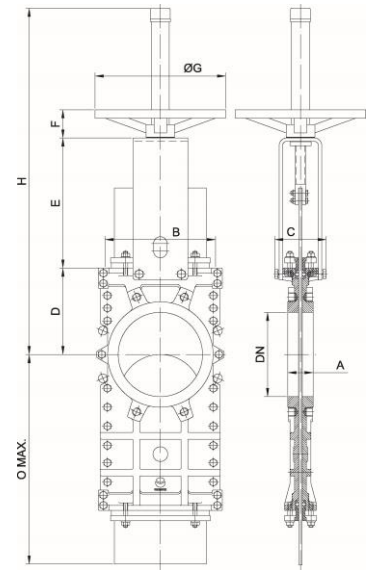

DIMENSIONS (mm) Handwheel Non Rising Stem

DN	Pressures	A	B	C	D	E	F	ØG	H	Ø max.
50	10 bar	40	152	125	110	144	63	225	317	232
65	10 bar	40	167	125	115	161	63	225	339	255
80	10 bar	50	182	125	124	177	63	225	364	310
100	10 bar	50	202	125	140	202	63	225	405	367
125	10 bar	50	216	125	150	226	63	225	439	432
150	8 bar	60	241	125	175	252	63	225	490	497
200	8 bar	60	294	142	205	317	73	310	595	635
250	8 bar	70	356	142	245	372	73	310	690	777
300	6 bar	70	410	142	280	422	73	310	775	905
350	6 bar	96	473	197	300	509	98	410	907	1047
400	6 bar	100	538	197	350	559	98	410	1007	1171
450	5 bar	106	588	201	420	611	98	550	1129	1301
500	4 bar	110	646	201	450	671	98	550	1219	1461
600	4 bar	110	754	201	530	771	98	550	1399	1711

DIMENSIONS (mm) Pneumatic Actuator (D/A)

DN	Pressures	A	B	C	D	Ø max.	E	F	G	H	Weight (kg.)	Standard Cyl. Connect.
50	10 bar	40	152	100	110	232	129	178	115	417	14	C100/62 1/4" G
65	10 bar	40	167	100	115	255	146	193	115	454	16	C100/77 1/4" G
80	10 bar	50	182	100	124	310	162	211	115	497	18	C100/95 1/4" G
100	10 bar	50	202	100	140	367	187	231	115	558	23	C100/115 1/4" G
125	10 bar	50	216	100	150	432	211	271	140	632	34	C125/143 1/4" G
150	8 bar	60	241	100	175	497	237	296	140	708	41	C125/168 1/4" G
200	8 bar	60	294	119	205	635	309	358	175	872	73	C160/220 1/4" G
250	8 bar	70	356	122	245	777	364	428	220	1037	105	C200/270 3/8" G
300	6 bar	70	410	122	280	905	414	478	220	1172	128	C200/320 3/8" G
350	6 bar	96	473	197	300	1047	510	549	277	1359	207	C250/375 3/8" G
400	6 bar	100	538	197	350	1171	560	599	277	1509	300	C250/425 3/8" G
450	5 bar	106	588	270	420	1301	608	680	382	1708	378	C300/475 1/2" G
500	4 bar	110	646	270	450	1461	668	730	382	1848	445	C300/525 1/2" G
600	4 bar	110	754	270	530	1711	796	880	444	2206	619	C350/625 3/4" G

